

CIRCUIT DIAGRAM

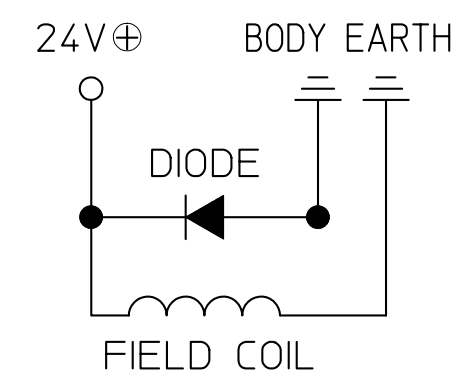

DETAIL OF ROTOR GROOVE(2:1)

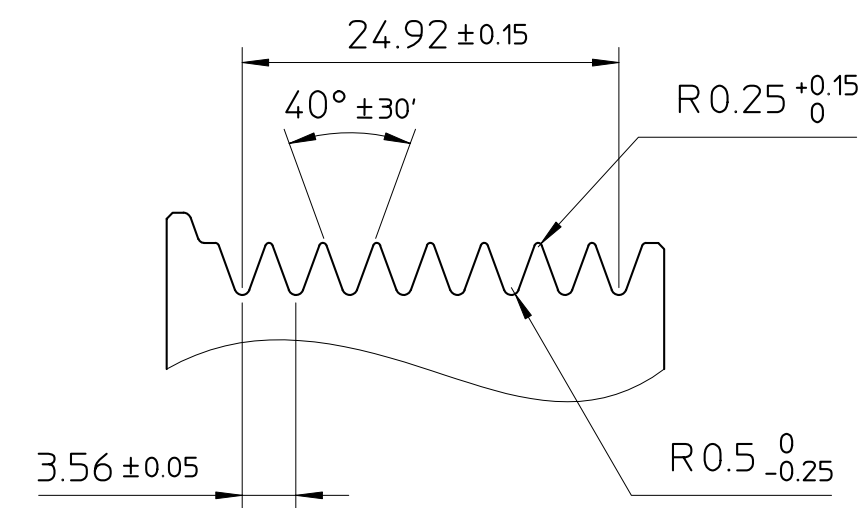

PARTIAL SECT. B-B (2:1)

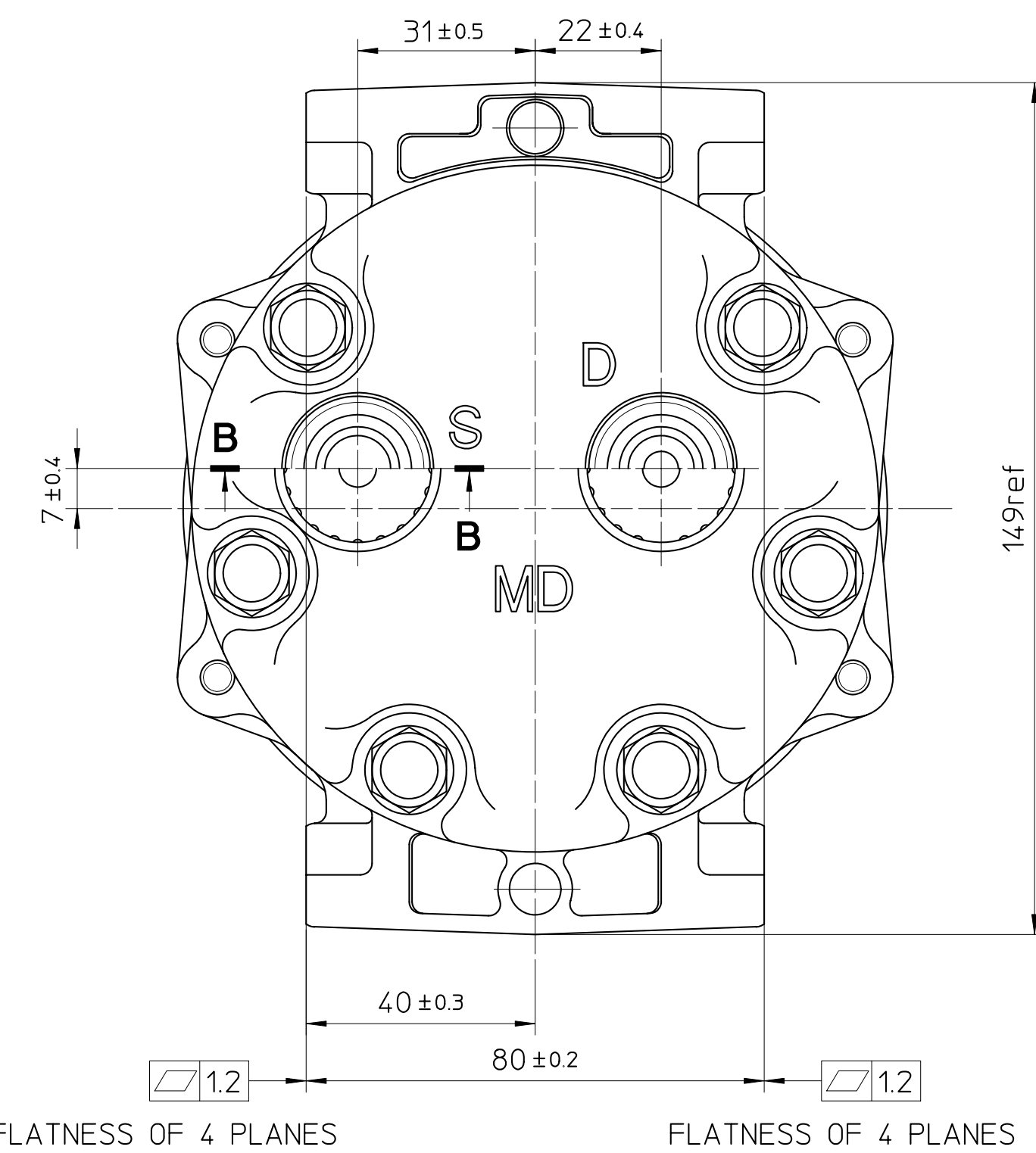
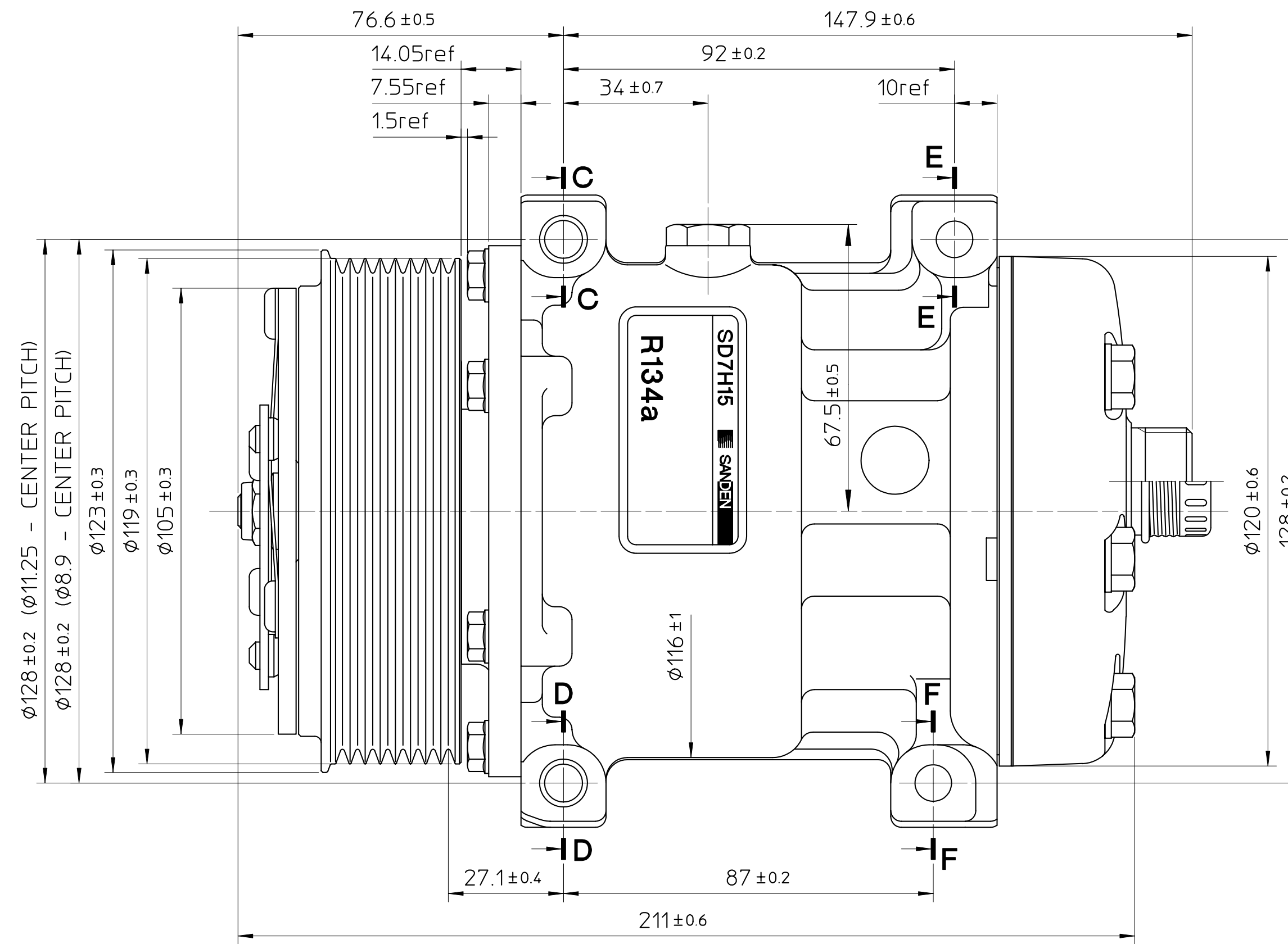
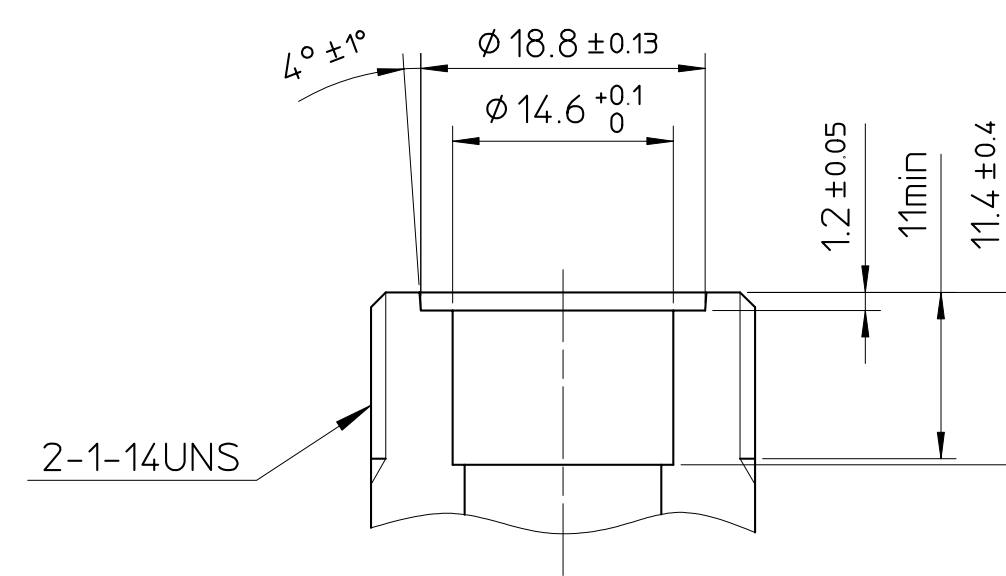

PARTIAL SECT. C-C

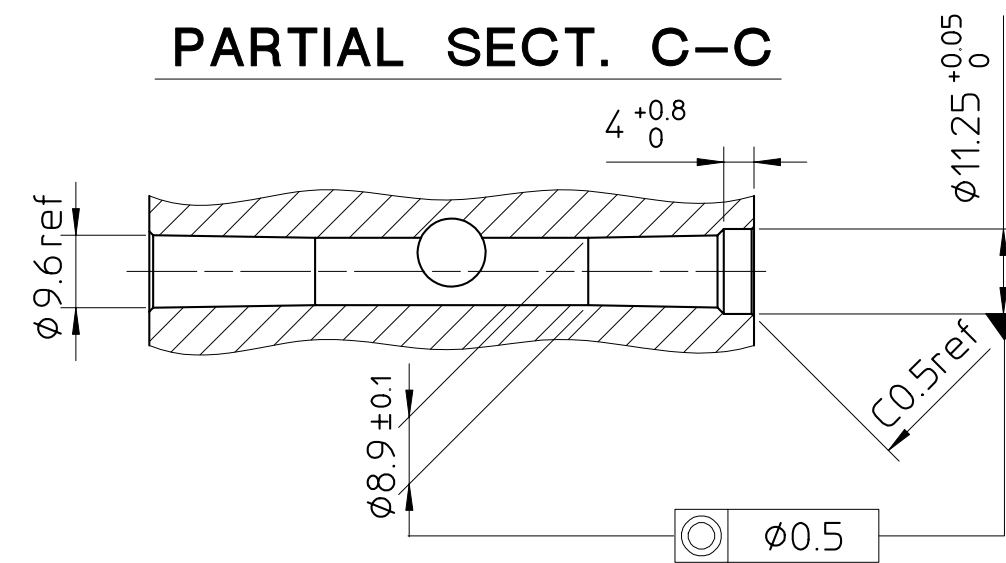

PARTIAL SECT. D-D

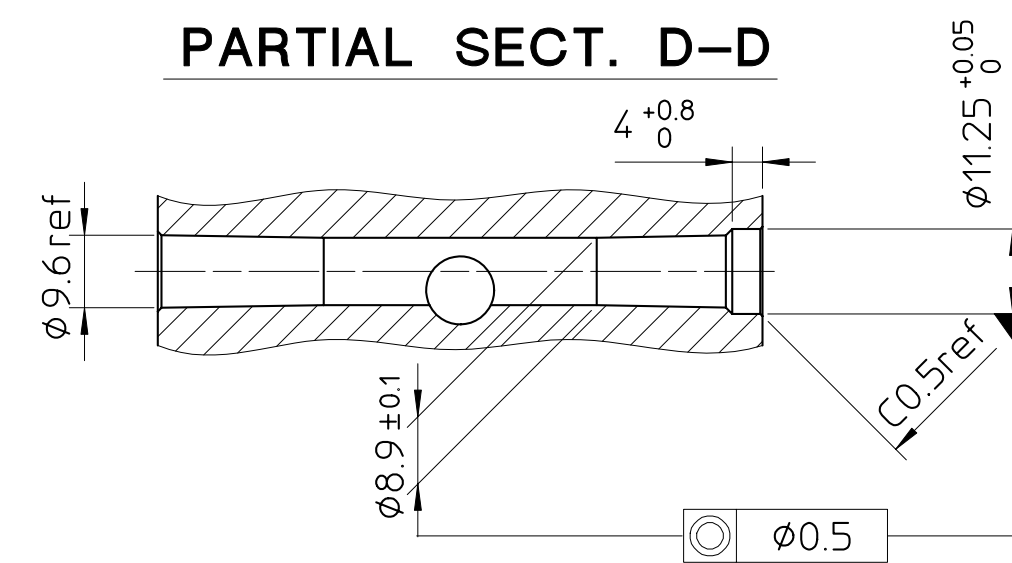

PARTIAL SECT. E-E

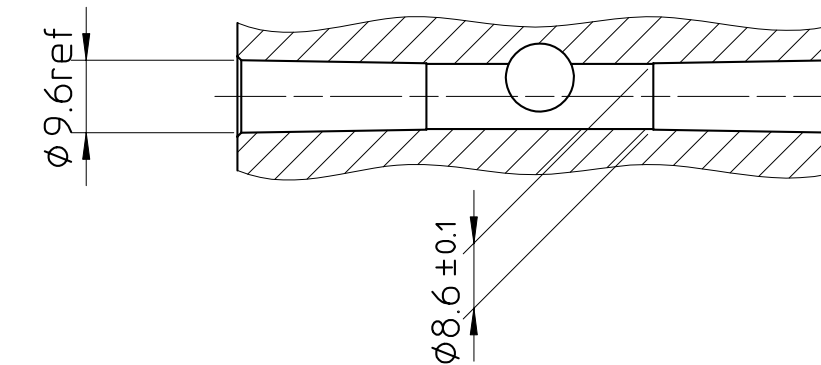

PARTIAL SECT. F-F

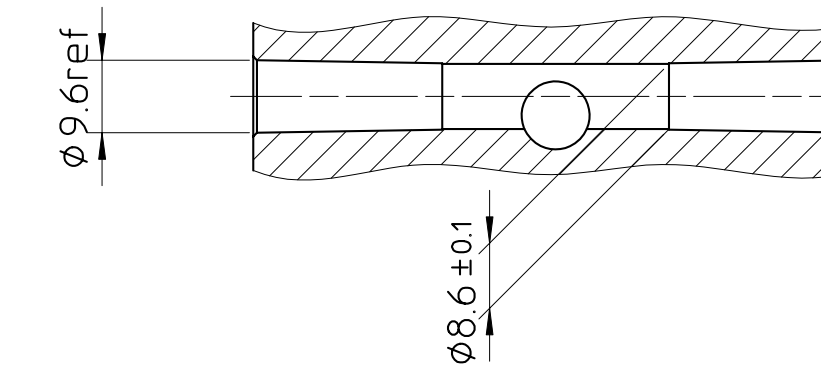

COMPRESSOR SPECIFICATIONS

BORE	Ø29.3	mm
STROKE	32.8	mm
NUMBER OF CYLINDERS	7	
DISPLACEMENT PER REVOLUTION	154.9	cm ³ /rev.
MAXIMUM ALLOWABLE CONTINUOUS SPEED	6000	r.p.m.
MAXIMUM DOWNSHIFT SPEED	7000	r.p.m.
REFRIGERANT	R134a	
OIL	SP-10 OR EQUIVALENT	
OIL CHARGE	△135	cm ³
ROTATION (CLUTCH SIDE VIEW)	CLOCKWISE	
WEIGHT		kg

CLUTCH SPECIFICATIONS

RATED VOLTAGE	DC 24	V
MINIMUM BREAKAWAY TORQUE	34.3	N·m
MINIMUM ENGAGEMENT VOLTAGE	DC 16	V
MAXIMUM POWER CONSUMPTION	42	W
MAXIMUM ALLOWABLE CONTINUOUS SPEED	6000	r.p.m.
MAXIMUM DOWNSHIFT SPEED	7000	r.p.m.
BELT TYPE	PV	TYPE
PULLEY DIAMETER	Ø119	mm
WEIGHT		kg

<table border="1"> <tr> <th>(t)</th> <th>0<</th> <th>3<</th> <th>6<</th> <th>30<</th> <th>120<</th> <th>315<</th> <th>1000<</th> <th>2000<</th> <th>3150<</th> <th>品質</th> <th>検査</th> </tr> <tr> <td>A</td> <td>0.05</td> <td>0.1</td> <td>0.15</td> <td>0.2</td> <td>0.3</td> <td>0.4</td> <td>0.7</td> <td>1.0</td> <td>-</td> <td>保証</td> <td>1</td> </tr> <tr> <td>B</td> <td>0.2</td> <td>0.3</td> <td>0.4</td> <td>0.5</td> <td>0.7</td> <td>1.0</td> <td>1.6</td> <td>2.5</td> <td>-</td> <td>保証</td> <td>2</td> </tr> <tr> <td>C</td> <td>0.4</td> <td>0.5</td> <td>0.6</td> <td>0.8</td> <td>1.2</td> <td>1.6</td> <td>3.0</td> <td>4.0</td> <td>-</td> <td>保証</td> <td>3</td> </tr> <tr> <td>D</td> <td>0.5</td> <td>0.8</td> <td>1.0</td> <td>1.2</td> <td>1.8</td> <td>2.8</td> <td>4.0</td> <td>6.0</td> <td>-</td> <td>保証</td> <td>-</td> </tr> <tr> <td>E</td> <td>1.0</td> <td>2.0</td> <td>2.5</td> <td>3.5</td> <td>5.0</td> <td>7.0</td> <td>10.0</td> <td>15.0</td> <td>-</td> <td>保証</td> <td>-</td> </tr> <tr> <td>F</td> <td>10.0</td> <td>15.0</td> <td>20.0</td> <td>30.0</td> <td>45.0</td> <td>75.0</td> <td>150.0</td> <td>250.0</td> <td>15%</td> <td>保証</td> <td>-</td> </tr> </table>		(t)	0<	3<	6<	30<	120<	315<	1000<	2000<	3150<	品質	検査	A	0.05	0.1	0.15	0.2	0.3	0.4	0.7	1.0	-	保証	1	B	0.2	0.3	0.4	0.5	0.7	1.0	1.6	2.5	-	保証	2	C	0.4	0.5	0.6	0.8	1.2	1.6	3.0	4.0	-	保証	3	D	0.5	0.8	1.0	1.2	1.8	2.8	4.0	6.0	-	保証	-	E	1.0	2.0	2.5	3.5	5.0	7.0	10.0	15.0	-	保証	-	F	10.0	15.0	20.0	30.0	45.0	75.0	150.0	250.0	15%	保証	-	<table border="1"> <tr> <th>年</th> <th>月</th> <th>日</th> <th>訂正</th> <th>記事</th> <th>担当者</th> </tr> <tr> <td>03</td> <td>7</td> <td>3</td> <td>CHANGE OF OIL AMOUNT</td> <td>保証</td> <td>保証</td> </tr> <tr> <td>No.</td> <td>DATE</td> <td>REVISION</td> <td>SIGN</td> <td>SIGN</td> <td>SIGN</td> </tr> </table>		年	月	日	訂正	記事	担当者	03	7	3	CHANGE OF OIL AMOUNT	保証	保証	No.	DATE	REVISION	SIGN	SIGN	SIGN	<table border="1"> <tr> <th>設計</th> <th>確認</th> <th>承認</th> <th>検査</th> <th>承認</th> </tr> <tr> <td>DESIGNED</td> <td>CHECKED</td> <td>APPROVED</td> <td>INSPECTED</td> <td>APPROVED</td> </tr> </table>		設計	確認	承認	検査	承認	DESIGNED	CHECKED	APPROVED	INSPECTED	APPROVED	<table border="1"> <tr> <th>材質</th> <th>表面</th> <th>仕上げ</th> </tr> <tr> <td>MATERIAL</td> <td>FINISH</td> <td>FINISH</td> </tr> </table>		材質	表面	仕上げ	MATERIAL	FINISH	FINISH
(t)	0<	3<	6<	30<	120<	315<	1000<	2000<	3150<	品質	検査																																																																																																																		
A	0.05	0.1	0.15	0.2	0.3	0.4	0.7	1.0	-	保証	1																																																																																																																		
B	0.2	0.3	0.4	0.5	0.7	1.0	1.6	2.5	-	保証	2																																																																																																																		
C	0.4	0.5	0.6	0.8	1.2	1.6	3.0	4.0	-	保証	3																																																																																																																		
D	0.5	0.8	1.0	1.2	1.8	2.8	4.0	6.0	-	保証	-																																																																																																																		
E	1.0	2.0	2.5	3.5	5.0	7.0	10.0	15.0	-	保証	-																																																																																																																		
F	10.0	15.0	20.0	30.0	45.0	75.0	150.0	250.0	15%	保証	-																																																																																																																		
年	月	日	訂正	記事	担当者																																																																																																																								
03	7	3	CHANGE OF OIL AMOUNT	保証	保証																																																																																																																								
No.	DATE	REVISION	SIGN	SIGN	SIGN																																																																																																																								
設計	確認	承認	検査	承認																																																																																																																									
DESIGNED	CHECKED	APPROVED	INSPECTED	APPROVED																																																																																																																									
材質	表面	仕上げ																																																																																																																											
MATERIAL	FINISH	FINISH																																																																																																																											
<table border="1"> <tr> <td>図面番号</td> <td>8144-6000</td> </tr> <tr> <td>名称</td> <td>COMPRESSOR</td> </tr> <tr> <td>用発形式名</td> <td>SD7H15MD8144</td> </tr> <tr> <td>MODEL</td> <td></td> </tr> </table>						図面番号	8144-6000	名称	COMPRESSOR	用発形式名	SD7H15MD8144	MODEL																																																																																																																	
図面番号	8144-6000																																																																																																																												
名称	COMPRESSOR																																																																																																																												
用発形式名	SD7H15MD8144																																																																																																																												
MODEL																																																																																																																													
<table border="1"> <tr> <td>三角法</td> <td>尺</td> <td>SCALE</td> <td>1:1</td> <td>製図年月日</td> <td>2002.02.04</td> </tr> <tr> <td>DATE</td> <td>DATE</td> <td>DATE</td> <td>DATE</td> <td>DATE</td> <td>DATE</td> </tr> </table>						三角法	尺	SCALE	1:1	製図年月日	2002.02.04	DATE	DATE	DATE	DATE	DATE	DATE																																																																																																												
三角法	尺	SCALE	1:1	製図年月日	2002.02.04																																																																																																																								
DATE	DATE	DATE	DATE	DATE	DATE																																																																																																																								